

FEATURES

- Instrument operated by a rotation "Encoder"
- Flow control input
- pH range: 0-14 pH
- PT100 Temperature probe
- pH probe
- Stand-by input
- Probe alarm (probe check-up)
- Max dosing time alarm
- Threshold alarm
- Level alarm
- Flow alarm
- SMS alarm sending (as option)
- Ethernet connection to email alarm condition (as option)
- Programmable delay at dosing startup (max 60 minutes)
- Temperature and pH compensation
- Service Menù for real time probe reading
- Real time internal clock
- Working modes: on/off, impulsive proportional, proportional PWM and fixed PWM
- Automatic or manual dosing activity
- Data log storage on USB device (as option)
- mA outputs (as option)

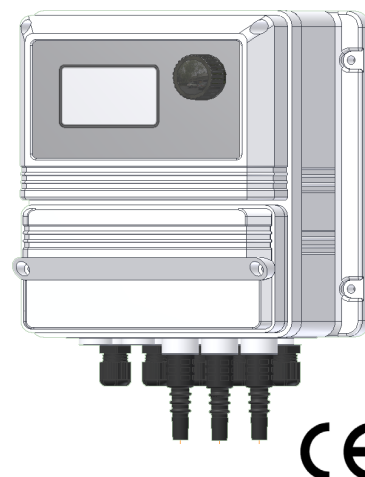

Microprocessor digital regulator for double pH with temperature reading.

On/Off, impulsive proportional, proportional PWM or fixed PWM working modes.

In On/Off working mode, a "STK Speed" function let the pumps operate at pulses per minutes for a set time (1 pulse every x minutes) to provide a reaction time.

INPUT:

- Stand-by
- Flow
- pH1 level
- pH2 level
- PH3 level
- Double pH probe
- Temperature probe
- Power supply

OUTPUT:

- 3 proportional impulsive (pH)
- 2 Proportional on/off (pH)
- General alarm
- mA output (pH and temperature) as option

ELECTRICAL

INPUT SIGNAL

BNC (pH)

ON/OFF OUTPUT

2 relays; 5A @ 230 VAC
(fuse protected)

ALARM OUTPUT

Free voltage contact
(fuse protected)

POWER SUPPLY

90-265 VAC; 50/60 Hz

PROPORTIONAL OUTPUT

Pulse output signal,
open collector

STAND-BY

1 contact input

AVERAGE CONSUMPTION

25 W

0-180 pulses per minute

RS485 OUTPUT
1 RS485 output
(optional)

EMEC

ISO 9001:2008
ISO 14001:2004
OHSAS 18001:2007



Via Donatori di sangue, 1 - 02100 Vazia (RI) - Italy
Tel. +39 0746 2284 1 - Tel. +39 0746 1725114 - Fax +39 0746 2284 2 - <http://www.emec.it>

Specifications subject to change without notice.
ENG R1-10-10

DIMENSIONS

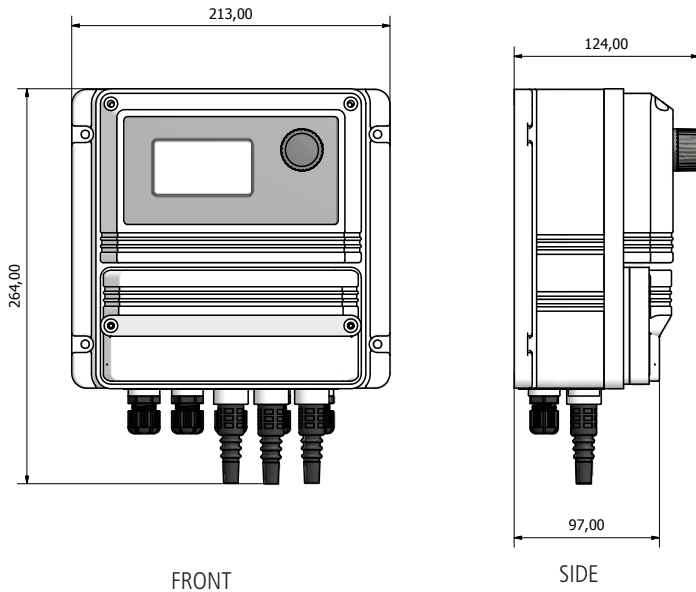

ENCLOSURE

IP65 enclosure (NEMA4x).

LDPPH control instruments are manufactured in ABS housing to ensure protection against aggressive chemicals and tough environment.

ENVIRONMENT

-10°C ÷ 50°C (14°F ÷ 122°F)

0÷95% (non condensing) relative humidity

PH PROBE - TEMPERATURE PROBE

PH PROBE	
EPHS	0-14 pH
TEMPERATURE PROBE	
ETEPT	0-100° C